

Understanding Infiltration Control



What is Infiltration?

Infiltration, or air leakage, occurs in all homes. Many believe houses need to breathe to have healthy indoor air quality. Ventilation is needed in certain areas of the home, so targeted measures such as kitchen and bathroom exhaust fans are used. But a house that breathes in humid, moldy crawlspace air or hot, dusty attic air is not healthy. While newer construction methods reduce infiltration, most all houses in the southeast exchange at least one-third of the volume of air in the home every hour (called air changes per hour or ACH). This rate can be four or five times higher for many older or poorly built homes. Through increased heating and cooling loads, air leaks waste hundreds of dollars on energy bills. But of equal concern are the increased moisture levels and the introduction of other contaminants such as dust and radon that air leakage paths can cause in homes. These same pathways also provide easy access for insects and other small pests.

A few holes in floors or walls alone are not enough for significant infiltration to occur. But in a complex system like a home, many variables such as wind, the home's "stack effect", pressure imbalances from duct leakage, or other forces push or pull conditioned air into or out of the home. Homes with two or more stories or fireplaces will always have greater infiltration rates. Since these forces occur constantly, reductions in infiltration rates can be achieved only by sealing the air leaks.

The Impact on Energy Bills

The average home likely has at least 0.8 ACH year-round. At this level, infiltration will account for nearly fifty percent of the heating load on the home when the temperature is below freezing and about

one quarter of the cooling load when temperatures exceed ninety degrees. Since the costs of materials and labor to properly seal a newly constructed home are relatively low, infiltration control constitutes a great investment.

Infiltration Control in New Homes

When it comes to sealing air leaks in a new home, timing is everything and there is no time like the present. After framed is complete and the electrical and plumbing contractors have finished, but before insulation is installed, you have the perfect opportunity to easily, effectively, and cheaply seal many air leaks. Never again will you have the opportunity to so easily and affordably impact home comfort and efficiency. As a general rule, if in doubt, foam it, caulk it, or weather-strip it.

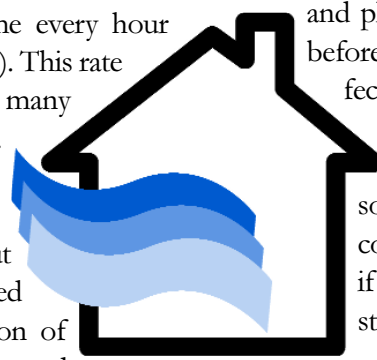

Even with the best carpentry skills, wooden boards cannot be attached to each other in an airtight fashion. And after the plumbers, electricians, and other

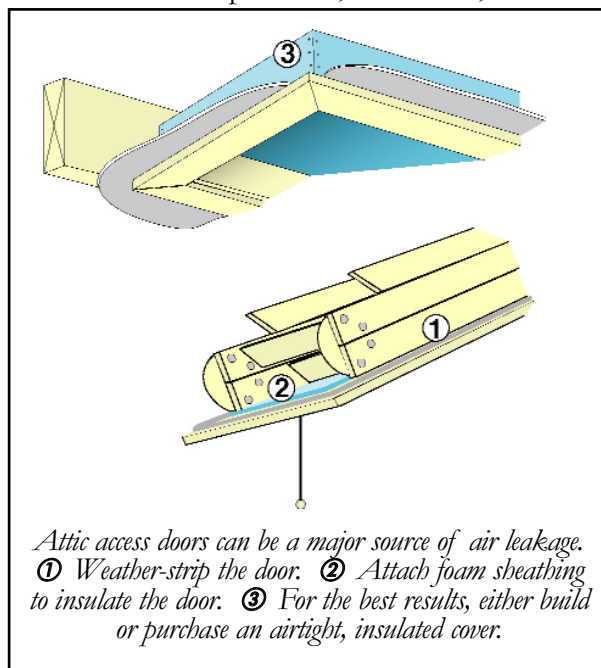

sub-contractors are through snaking pipes and wires through your new home, nearly half of the wall cavities will have at least one penetration. However, most insulation contractors offer infiltration sealing as a basic service before installing wall insulation. For do-it-yourselfers, with a case of foam and caulk and far less than a day of relatively easy labor, you can significantly reduce the operating costs of a new home.

What About Existing Homes?

If your home was built prior to 1990, you could have serious infiltration issues. Here's a checklist of some simple solutions for air leakage in a typical home.

- Weather-strip and insulate attic access doors or disappearing stairways.
- Fabricate a whole-house fan cover from rigid insulation board or purchase a ready-made cover.
- Weather-strip all doors between conditioned and unconditioned areas.
- Inspect window weather-stripping and replace whenever necessary.
- Inspect and regularly re-caulk windows and doors.

- From the crawlspace or basement, seal all plumbing or electrical penetrations through the floor with an expandable foam (isocyanurate). Cover and seal any access holes beneath tubs or showers.
- Check around electrical switches and outlets for drafts. If you cannot seal the penetrations causing an air leak, purchase and install electrical cover-plate gaskets to reduce infiltration.
- Inspect wood framed air-conditioning returns for penetrations or gaps in the wood framing. Seal any leaks with acrylic mastic.
- Check air-conditioning supply registers in the floor for leakage where the ducts connect to the floor.

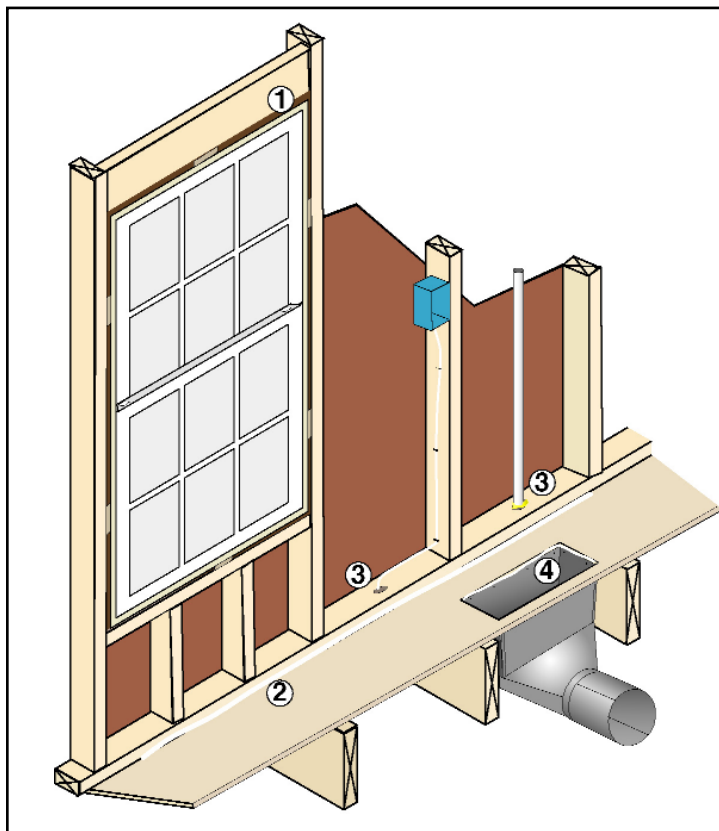
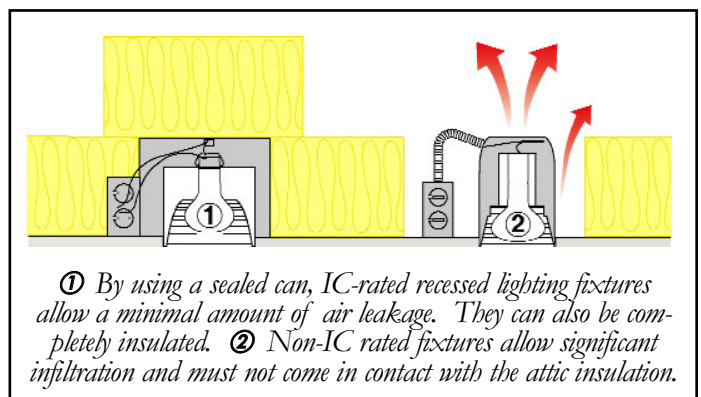

Infiltration Fixes for New Construction

- ① Window and door shim spaces, the area between the window or door and the surrounding framing, should be sealed and insulated. Instead of forcing scraps of fiberglass insulation into this area, use a minimal expansion foam. The foam is impervious to infiltration and offers an insulation value of R-5 or higher. Apply the foam slowly, making sure not to warp window or door frames as the foam expands.
- ② Use caulk to seal air leaks between the sole plate and the floor decking.
- ③ Use expandable foam to seal all electrical or plumbing penetrations through the wall framing top plate or sole plate. Also, check for large openings underneath tubs, showers, or fireplaces. Wood and/or foam sheathing covers may be needed to close these large openings.
- ④ Connections of galvanized metal ductwork to floors, ceilings, or walls should be sealed with mastic or caulk. While these measures should be completed by the HVAC contractor, left uncorrected, air-leakage into ductwork can magnify infiltration rates and drastically reduce HVAC system efficiency.